



Department of Public Service
5330 Seaman Road
Oregon, Ohio 43616
(419) 698-7047
FAX (419) 691-0241

January 19, 2023

ADDENDUM No. 2

**LUC – MUNDING DRIVE AND DEARBORN AVENUE RECONSTRUCTION
PID 111524**

**CITY OF OREGON
DEPARTMENT OF PUBLIC SERVICE**

BIDS TO BE OPENED: Thursday, January 26, 2023 at 2:00 PM

Plan holders of the City of Oregon's LUC- Munding Drive and Dearborn Avenue Reconstruction are hereby notified of the following amendments to the Contract Documents. The following additions, alterations, deletions and/or clarifications shall be part of the bid specifications as much as if they were originally included in the Contract Documents. This Addendum No. 2 is hereby made a part of the Contract Documents.

CONTRACT CHANGES

1) PROJECT BID FORM

Replace PAGES 14, 15 and 16 in the Project Bid Book with the attached **REVISED PROJECT BID FORMS – REVISED PAGES 14, 15 AND 16 DATED 1/19/2023.**

2) PROJECT SPECIFICATIONS

Replace PAGES GC3 and GC5 in the Project Bid Book with the attached **REVISED PAGES GC3 AND GC5 DATED 1/19/2023** that deleted some language.

3) PLAN REVISIONS

Replace PLAN SHEETS 3, 5, 6 AND 7 in the Plan Set with the attached **REVISED PLAN SHEETS 3, 5, 6 AND 7 DATED 1/19/2023.**

ANSWERS TO SUBMITTED QUESTIONS

Question #1 – Would slipping the curb as Type 2 be an acceptable replacement for the Type 2A being poured monolithically?

The plans and specifications have been revised to allow an alternative **Type 2A, APP**, which would be per the **Type 2 Curb, APP** detail and paid per LF. The pay limits of the **8" Non-Reinforced Concrete Pavement (MS), APP** would also not change.

Question #2 – How will Subgrade Compaction be paid at the proposed driveways? Will aggregate base be required at the proposed driveways? If so, how thick? How will the aggregate base be measured and paid?

A note has been added to the plans to indicate that subgrade compaction and aggregate base for concrete drives shall be incidental to the **6" and 8" Non-Reinforced Concrete Pavement for Driveways (MS), APP** pay references.



Department of Public Service
5330 Seaman Road
Oregon, Ohio 43616
(419) 698-7047
FAX (419) 691-0241

Question #3 – How should be new concrete be tied into existing concrete?

The new concrete shall be tied into existing concrete at the project limits per ODOT detail SCD BP-2.5.

Question #4 – Specification 451.10 Finishing discusses surface tining. Will the City of Oregon approve the use of transverse tining for the project?

Yes. Plan note for the 8" **Non-Reinforced Concrete Pavement (MS)**, **APP** has been updated to allow transverse tining for the project. Longitudinal tining will not be required.

*** * * END OF ADDENDUM NO. 2 * * ***

Paul Roman, P.E
Director of Public Service

BID FORM

To the Director of Public Service
Municipal Building
5330 Seaman Road
Oregon, Ohio 43616-2633

I. The undersigned, having familiarized _____ with the local conditions affecting the cost of the work and with the Contract Documents, hereby proposes to perform everything required to be performed and to provide and furnish all of the labor, materials, necessary tools, expendable equipment, and all utility and transportation services necessary to perform and complete in a workmanlike manner all of the work required for the reconstruction of 0.30 miles of Munding Drive from S.Wheeling Street to Navarre Avenue and 0.37 miles of Dearborn Avenue from Navarre Avenue to S. Wheeling Street. The project also includes roadway, excavation, aggregate base, drainage, pavement markings, erosion control items, and miscellaneous work required to complete the project for the CITY OF OREGON, OHIO, all in accordance with the specifications for the following prices, to wit:

Project Bid: **LUC-MUNDING DRIVE AND DEARBORN AVENUE RECONSTRUCTION (PID 111524)**

<u>REF. NO.</u>	<u>ODOT ITEM#</u>	<u>ITEM DESCRIPTION</u>	<u>QTY</u>	<u>UNIT</u>	<u>PRICE BID</u>	<u>AMOUNT BID</u>
		ROADWAY				
1	202	Driveway Removed	852	SF		
2	202	Concrete Curb Removed	6,493	LF		
3	202	Concrete Pavement Removed	9,818	SY		
4	202	Catch Basin, Removed	18	EA		
5	202	Storm Sewer, Removed	268	LF		
6	203	Excavation	3,573	CY		
7	204	Subgrade Compaction	9,818	SY		

<u>REF. NO.</u>	<u>ODOT ITEM#</u>	<u>ITEM DESCRIPTION</u>	<u>QTY</u>	<u>UNIT</u>	<u>PRICE BID</u>	<u>AMOUNT BID</u>
8	204	Proof Rolling	6	HR		
9	609	Curb, Type 2A (MS), <i>AS PER PLAN</i>	6,493	LF		
		EROSION CONTROL				
10	SPEC	Inlet Protection, APP	18	EA		
11	659	Seeding and Mulching	1,860	SY		
12	832	Storm Water Pollution Prevention Plan, APP	1	LS		
13	832	Storm Water Pollution Prevention Inspections	1	LS		
14	832	Erosion Control	2,000	EA	\$1.00	\$2,000.00
		DRAINAGE				
15	605	6" Base Pipe Underdrains, APP	6,543	LF		
16	611	Catch Basin No. 3A	18	EA		
17	611	12" Conduit, Type B (706.02)	196	LF		
18	611	15" Conduit, Type B (706.02)	72	LF		
		PAVEMENT				
19	SPEC	Geotextile Fabric, Type D	9,818	SY		
20	204	Granular Material, Type C	300	CY		
21	304	Aggregate Base	3,273	CY		
22	452	8" Non-Reinforced Concrete Pavement (MS), <i>AS PER PLAN</i>	9,818	SY		

<u>REF. NO.</u>	<u>ODOT ITEM#</u>	<u>ITEM DESCRIPTION</u>	<u>QTY</u>	<u>UNIT</u>	<u>PRICE BID</u>	<u>AMOUNT BID</u>
23	452	8" Non-Reinforced Concrete Pavement for Driveways (MS), <i>AS PER PLAN</i>	537	SF		
24	452	6" Non-Reinforced Concrete Pavement for Driveways (MS), <i>AS PER PLAN</i>	315	SF		
		TRAFFIC CONTROL				
25	642	Lane Line, 4"	0.66	Mile		
26	642	Channelizing Line, 4"	75	FT		
27	642	Lane Arrow	4	EA		
		MISCELLANEOUS				
28	614	Maintaining Traffic	1	LS		
29	623	Construction Staking	1	LS		
30	624	Mobilization	1	LS		

TOTAL PROJECT BID IN FIGURES \$ _____
(Unofficial total subject to correction)

II. Time of Completion. The undersigned agrees to substantially complete the work covered by the contract by **August 18, 2023**.

1. STAKING - The Contractor shall establish and be responsible for all line and grade. The Owner and his representative shall at all times have access to the work and the Contractor shall provide proper facilities for such access and inspection.
2. MATERIALS, TOOLS, TESTING - The Contractor shall furnish all the necessary materials, apparatus, tools and labor. Materials and apparatus shall be new and the best of their respective kinds, and shall be subject to such standard tests as the Owner may select in determining the fitness and durability of the materials and apparatus to be furnished. Except as otherwise indicated, inspection and testing of materials shall be provided by the Owner. The tools shall be suitable for the purpose intended; and all labor shall be performed in an expeditious, thorough and workmanlike manner; all in accordance with these Specifications, and the direction of the City and subject to the approval of the Owner.
3. DEFECTIVE MATERIALS - Should any of the materials, when delivered upon the locations of the work, be found defective or not in accordance with these specifications, they shall be immediately removed by the Contractor, otherwise the Owner may cause the same to be removed at the Contractor's expense.
4. MATERIAL STORAGE - All materials, delivered or found upon the location of the improvement, shall be snugly piled up so as not to impede travel upon walks or driveways, interfere with the operations of any other contractor or prevent the use of any fire hydrant more than is actually necessary to the proper performance of this Contract.
5. MATERIALS, SERVICES AND FACILITIES - EXTRA HOURS -
 - a. It is understood that, except as otherwise specifically stated in the Contract Documents, the Contractor shall provide and pay for all materials, labor, tools, equipment, water, light, power, transportation, superintendence, temporary construction of every nature and all other services and facilities of every nature whatsoever necessary to execute, complete and deliver the work within the time stipulated in the Contract.
 - b. Any work necessary to be performed after regular working hours, on Sundays or legal holidays shall be performed without additional expense to the Owner.
6. "OR EQUAL" CLAUSE - Whenever in any of the Contract Documents an article, material or equipment is defined by describing a proprietary product or by using the name of a manufacturer or vendor, the term "or equal" if not inserted, shall be implied. The specified article, material or equipment mentioned shall be understood as indicating the type, function, minimum standard or design, efficiency and quality desired and shall not be construed in such a manner as to exclude manufacturer's products of comparable quality, design and efficiency. The Contractor shall comply with the requirements of the Contract Documents relative to the Owner's approval of materials and equipment before they are incorporated in the Project.
7. BODILY INJURY AND PROPERTY DAMAGE INSURANCE
 - a. The Contractor shall provide insurance for the following coverages:
 - i. Comprehensive Public Liability and Property Damage, Contractor's Protective Liability, ~~with the City and FirstEnergy Corp. and its subsidiaries and affiliates listed as additional insured~~, Contractual Liability, Completed Operations - Products, Automobile Bodily Injury and Property Damage Liability, including owned, non-owned and hired vehicles-

Commercial General Liability Insurance. The minimum limits for liability insurance are as follows:

General Aggregate Limit	\$2,000,000
-------------------------	-------------

from the Contractor's operations under this Contract, whether such operations be by himself or by any Subcontractor or anyone directly or indirectly employed by any of them may be legally liable.

- ~~h. Any combination of the Contractor's coverage limits, including umbrella excess liability limits shall provide no less than \$1,000,000 single limit bodily injury and property damage liability coverage. The same limit shall apply to the Owner's Protective Liability Policy.~~
- i. Insurance shall be provided by an insurance company authorized to do business in the State in which the Project is located for all of the required coverages, shall be approved by the Owner and shall remain in force until the date of final payment for the project. Before starting work, the Contractor shall furnish five (5) copies of certificates certifying the required coverages. Policies (and certificates) shall contain the following endorsements: "The company agrees that 15 days prior to cancellation or reduction of the insurance afforded by this policy with respect to the Contract involved, written notice will be mailed to the Owner".
14. BUILDER'S RISK INSURANCE - The Contractor shall take out and maintain Builder's Risk Insurance, if applicable, including fire, extended coverage, vandalism and malicious mischief and theft, on the insurable portion of the Project. Such insurance shall be in an amount which may vary with the extent of the work completed, but shall at all times be at least equal to the amount previously paid by the Owner on account of work and materials, plus the value of work and materials furnished or delivered by the Contractor but not paid for the Owner. Insurance shall be issued in the names of the Owner and the Contractor as joint insured as their interests may appear, and remain in full force and effect until the date of final payment for the Project. The provisions of Paragraph 13.I., insofar as approval of policies, providing of certificates and cancellation notification are concerned, shall apply to Builder's Risk Insurance and All Risk Installation floater policies.
15. WORKER'S COMPENSATION INSURANCE - The Contractor and any Subcontractors shall take out and maintain such insurance as will protect them from claims under Worker's Compensation laws, disability benefit laws or other similar employee benefit laws and from claims for damages because of bodily injury, occupational sickness or disease, or death of their employees. Proof of compliance with Worker's Compensation laws and Social Security laws shall be filed with the Owner until the date of final payment for the Project and the Contractor shall indemnify and save harmless the Owner from any contributions or taxes, or liability therefor.
16. ROYALTIES AND PATENT INFRINGEMENTS - The Contractor shall indemnify and save harmless the Owner from any and all suits and expense over and above the expense included in the Contract price for royalties or infringements on patents that may be involved in the construction of the appliances contracted for, or any of the parts thereof, or in the use of said appliances or any of the parts thereof hereafter, and said Contractor shall defend, at his proper cost and expense, any and all suits and actions of every kind whatsoever, that may be brought against the indemnified parties by reason of the construction or use of said appliances, or any of the parts thereof.
17. TIME FOR BEGINNING AND COMPLETION - The work shall be commenced at the time stated in the notice to the Contractor to proceed and shall be completed within the time limit stipulated in the Bid and Contract.
18. CONTRACT SECURITY - The Contractor shall furnish a Bid Guaranty Bond or a Performance Bond in an amount of at least equal to 100 percent of the Contract price as security for the faithful performance of this Contract.
19. ASSIGNMENTS - The contractor shall not assign the whole or any part of this Contract or any monies due or to become due hereunder without written consent of the Owner. In any case the Contractor assigns all or any part of any monies due or to become due under this Contract, the instrument of assignment shall contain a clause substantially to the effect that it is agreed that the right of the assignees in and to any

ROADWAY

REMOVAL ITEMS

PAYMENT FOR REMOVAL OF ALL EXISTING OBSTRUCTIONS WHICH ARE NOT ITEMIZED SEPARATELY IN THE PLANS FOR PAYMENT AND WHICH WOULD NORMALLY BE REMOVED FOR THE INSTALLATION OF NEW WORK SHALL BE INCLUDED IN THE UNIT PRICE BID FOR THE PERTINENT ITEM OF NEW WORK.

01/19/23

CURB TYPE 2A (MS), APP

CURB TYPE 2, APP MAY BE USED IN LIEU OF CURB TYPE 2A. PAY ITEMS AND QUANTITIES SHALL REMAIN THE SAME

01/11/23

PAVEMENT

8" NON-REINFORCED CONCRETE PAVEMENT (MS), APP

THIS WORK CONSISTS OF CONSTRUCTING A NON-REINFORCED PORTLAND CEMENT CONCRETE PAVEMENT ON A PREPARED SURFACE.

THE REQUIREMENTS OF 452 & 451 APPLY, EXCEPT AS FOLLOWS:

THE USE OF A SLIP FORM PAVER SHALL NOT BE REQUIRED FOR THIS PROJECT.

01/19/23

LONGITUDINAL TINGING WILL NOT BE REQUIRED.

NON-REINFORCED CONCRETE PAVEMENT FOR DRIVEWAYS (MS), APP

SUBGRADE COMPACTION AND AGGREGATE BASE NECESSARY TO LEVEL SHALL BE INCIDENTAL TO NON-REINFORCED CONCRETE PAVEMENT FOR DRIVEWAYS (MS).

01/19/23

PROFILE AND ALIGNMENT

THE PROPOSED PAVEMENT REPLACEMENT SHALL FOLLOW THE ALIGNMENT AND PROFILE OF THE EXISTING PAVEMENT AND AS DETERMINED BY THE WORK SHOWN IN THE TYPICAL SECTION.

MAINTENANCE OF TRAFFIC

MAINTAINING TRAFFIC

METHODS OF MAINTAINING TRAFFIC SHALL BE IN ACCORDANCE WITH ITEM 614, THE "OHIO MANUAL OF UNIFORM TRAFFIC CONTROL DEVICES" (THE OHIO MANUAL) AND THE FOLLOWING:

THE CONTRACTOR SHALL MAINTAIN LOCAL TRAFFIC AT ALL TIMES OF ROAD CONSTRUCTION. THE CONTRACTOR SHALL PROVIDE, ERECT AND MAINTAIN THE FOLLOWING SIGNS AS PER OHIO MANUAL

- A) "ROAD WORK AHEAD" (48' X 48", W20-1)
- B) "END ROAD WORK" (36' X 18", G20-2A)

TRAFFIC CONTROL DEVICES SHALL BE SET UP PRIOR TO THE START OF CONSTRUCTION AND SHALL BE PROPERLY MAINTAINED DURING THE TIME SUCH SPECIAL CONDITIONS EXIST. THEY SHALL REMAIN IN PLACE ONLY AS LONG AS THEY ARE NEEDED AND SHALL BE IMMEDIATELY REMOVED THEREAFTER. ALL SIGNS WITH MESSAGES WHICH DO NOT APPLY DURING A CERTAIN PERIOD SHALL BE COVERED OR SET ASIDE OUT OF VIEW OF TRAFFIC. ALL TRAFFIC CONTROL DEVICES SHALL BE KEPT IN PROPER POSITION, CLEAN, LEGIBLE AND IN GOOD WORKING CONDITION AT ALL TIMES.

DRIVEWAY ACCESS SHALL BE MAINTAINED AT ALL PERIODS OF CONSTRUCTION BY USE OF EXISTING AND PROPOSED PAVEMENT, BERMS, OR SHOULDERS TO THE SATISFACTION OF THE ENGINEER. THE CONTRACTOR SHALL PROVIDE RESIDENTS AND/OR BUSINESSES WITH A MINIMUM FORTY-EIGHT (48) HOUR NOTICE WHEN ACCESS TO THEIR DRIVEWAYS WILL BE RESTRICTED DUE TO CONSTRUCTION.

PAYMENT FOR MAINTAINING TRAFFIC WILL BE MADE IN ACCORDANCE WITH ITEM 614, AND WILL INCLUDE FULL

COMPENSATION FOR PROVIDING, ERECTING, MAINTAINING, AND REMOVING ADEQUATE TRAFFIC CONTROL SIGNS, BARRICADES, FLAGGERS, DRUMS AND LIGHTS AS SPECIFIED HEREIN AND AS DIRECTED BY THE ENGINEER.

THE CONTRACTOR SHALL PROVIDE TEMPORARY PAVEMENT MARKINGS FOR TRAFFIC CONTROL. THE MARKINGS SHALL CONSIST OF TAPE MATERIAL, 4-INCHES WIDE AND APPROXIMATELY 6-INCHES IN LENGTH SET AT NORMAL SPACING OF 50- FEET. IN CONGESTED AREAS, THE SPACING SHALL BE REVISED TO 25- FEET. TEMPORARY MARKINGS SHALL BE PROVIDED FOR THE WHITE LANE LINES AND YELLOW CENTERLINES. THE COST FOR TEMPORARY PAVEMENT MARKINGS SHALL BE INCLUDED IN THE LUMP SUM PRICE FOR MAINTENANCE OF TRAFFIC. THE CONTRACTOR SHALL FURNISH ALL LABOR, MATERIALS, AND EQUIPMENT REQUIRED TO INSTALL TEMPORARY PAVEMENT MARKINGS ON ALL MAJOR STREETS AS DIRECTED BY THE CITY.

THE CONTRACTOR SHALL COMPLY WITH THE MAINTENANCE OF TRAFFIC NOTES AND CONSTRUCTION PHASING PER THE PLANS. THE CONTRACTOR SHALL COORDINATE WITH THE CITY OF OREGON AND OTHER LOCAL GOVERNMENTS, IF NECESSARY, FOR THE ESTABLISHMENT OF APPROPRIATE LOCAL DETOUR ROUTES, AND TO ACCOMMODATE ANY AND ALL LOCAL SPECIAL EVENTS OR FESTIVALS.

THE CONTRACTOR SHALL PROVIDE THE CITY OF OREGON WITH WRITTEN NOTICE OF ANY DETOUR, LANE CLOSURES, AND OTHER CONSTRUCTION RELATED ACTIVITIES THAT WOULD CAUSE INCONVENIENCES TO THE TRAVELING PUBLIC. THE WRITTEN NOTICE SHALL BE PROVIDED A MINIMUM OF 14 DAYS IN ADVANCE SO THAT THE GENERAL PUBLIC, LOCAL EMERGENCY SERVICES AND OFFICIALS, INCLUDING POLICE, FIRE, AND LOCAL SCHOOLS CAN BE INFORMED AND UPDATED ON THE PROJECT CONSTRUCTION DETAILS BY THE CITY OF OREGON THROUGH THE USE OF PRESS RELEASES TO LOCAL MEDIA OUTLETS.

CONTRACTOR SHALL PROVIDE AND INSTALL ALL APPROPRIATE DETOUR SIGNAGE INCLUDING PLACING CLOSED SIGNS ON OVERHEAD SIGNS ON NAVARRE AVENUE AND WHEELING STREET. CLOSED SIGNS SHALL BE ATTACHED TO EXISTING OVERHEAD SIGNS WITH SELF TAPPING SCREWS.

ANY NECESSARY TRAFFIC SIGNAL TIMING CHANGES WILL BE DONE BY THE CITY OF OREGON.

PEDESTRIAN ACCESS SHALL BE MAINTAINED AT ALL TIMES THROUGH THE CONSTRUCTION ZONE.

EXISTING TRAFFIC CONTROL SIGNS

ALL REGULATORY AND WARNING SIGNS, IF REMOVED FOR CONSTRUCTION PURPOSES, SHALL BE IMMEDIATELY RESET. INSTALLATION MAY BE PERMANENT OR TEMPORARILY MOUNTED. THE MOUNTING DIMENSIONS MUST CONFORM TO OMTCD.

THE CONTRACTOR SHALL BE RESPONSIBLE FOR THE PROTECTION OF THE SIGNS. COSTS TO REPLACE DAMAGED OR LOST SIGNS SHALL BE DEDUCTED FROM PAYMENTS. IF THE CONTRACTOR DOES NOT IMMEDIATELY RESET REGULATORY AND WARNING SIGNS AS DIRECTED, THE CITY SHALL RESET THEM AND THE COSTS SHALL ALSO BE DEDUCTED FROM PAYMENTS TO THE CONTRACTOR.

CONSIDER THE COST OF THIS WORK AS INCIDENTAL TO THE PROJECT AND SHALL BE INCLUDED IN THE COST OF PERTINENT PAY ITEMS.

CONSTRUCTION SEQUENCING

STAGE 1

CLOSE ENTIRE ROADWAY ON MUNDING DRIVE BETWEEN STA. 1+95 TO STA. 14+50.

STAGE 2

CLOSE ENTIRE ROADWAY ON MUNDING DRIVE BETWEEN STA. 14+50 TO STA. 17+60.

STAGE 3

CLOSE ENTIRE ROADWAY ON DEARBORN AVENUE BETWEEN STA. 51+15 TO STA. 62+00. MAINTAIN ACCESS TO HOMES EXCEPT DURING POURING AND CURING OF CONCRETE.

STAGE 4

CLOSE ENTIRE ROADWAY ON DEARBORN AVENUE BETWEEN STA. 62+00 TO 70+52. MAINTAIN ACCESS TO HOMES EXCEPT DURING POURING AND CURING OF CONCRETE.

MUNDING DRIVE AND DEARBORN AVENUE CANNOT BE CLOSED CONCURRENTLY.

SCALE

DATE
8/12/2021

DRAWN: BEB
CHECKED: RMS

GENERAL NOTES

LUC - MUNDING DRIVE AND DEARBORN AVENUE RECONSTRUCTION

3
18

01/19/23

GENERAL SUMMARY								
REF NO.	SHEET NO.	QUANTITY	CONTINGENCY QUANTITY	ITEM	ITEM EXT.	TOTAL QUANTITY	UNIT	DESCRIPTION
ROADWAY								
1	6	852		202	32000	852	SF	Driveway Removed
2	6	6493		202	32000	6493	LF	Concrete Curb Removed
3	6	9818		202	23000	9818	SY	Concrete Pavement Removed
4	6	18		202	58100	18	EA	Catch Basin, Removed
5	6	268		202	34900	268	LF	Storm Sewer, Removed
6	6	3273	300	203	10000	3573	CY	Excavation
7	6	9818		204	10000	9818	SY	Subgrade Compaction
8	6	6		204	45000	6	HR	Proof Rolling
9	6	6493		609	14000	6493	LF	Curb, Type 2A (MS), APP
EROSION CONTROL								
10		18		SPEC		18	EA	Inlet Protection, APP
11		1860		659	10000	1860	SY	Seeding and Mulching
12	4	1		832	15001	1	LS	Storm Water Pollution Prevention Plan, APP
13		1		832	15002	1	LS	Storm Water Pollution Prevention Inspections
14		0	2000	832	30000	2000	EA	Erosion Control
DRAINAGE								
15	6	6543		605	14000	6543	LF	6" Base Pipe Underdrains, APP
16	6	18		611	98180	18	EA	Catch Basin No. 3A
17	6	196		611	04400	196	LF	12" Conduit, Type B (706.02)
18	6	72		611	05900	72	LF	15" Conduit, Type B (706.02)
PAVEMENT								
19	6	9818		SPEC		9818	SY	Geotextile Fabric, Type D
20	2	0	300	204	30020	300	CY	Granular Material, Type C
21	6	3273		304	20000	3273	CY	Aggregate Base
22	6	9818		452	12050	9818	SY	8" Non-Reinforced Concrete Pavement (MS), APP
23	6	537		452	12050	537	SF	8" Non-Reinforced Concrete Pavement for Driveways (MS), APP
24	6	315		452	10050	315	SF	6" Non-Reinforced Concrete Pavement for Driveways (MS), APP
TRAFFIC CONTROL								
25	6	0.66		642	00200	0.66	Mile	Lane Line, 4"
26	6	75		642	00400	75	FT	Channelizing Line, 4"
27	6	4		642	01300	4	EA	Lane Arrow
MISCELLANEOUS								
28		1		614	11000	1	LS	Maintaining Traffic
29		1		623	10000	1	LS	Construction Staking
30		1		624	10000	1	LS	Mobilization

SCALE
 DATE 8/12/2021
 DRAWN: BEB
 CHECKED: RMS
 GENERAL SUMMARY
 LUC - MUNDING DRIVE AND DEARBORN AVENUE RECONSTRUCTION
 5
 18

01/19/23

2

PAVEMENT CALCULATIONS												
LOCATION	LENGTH	DIMENSIONS			202	202	203	204	SPEC	304	452	609
		AVERAGE PROPOSED PAVEMENT WIDTH	INTERSECTION AREA	PAVEMENT REMOVED	CURB REMOVED	EXCAVATION	SUBGRADE COMPACTION	GEOTEXTILE FABRIC, TYPE D	AGGREGATE BASE	8" NON-REINFORCED CONCRETE PAVEMENT (MS), APP	CURB, TYPE 2-A (MS), APP	
FROM	TO	FOOT	SQ. FT.	SY	LF	CY	SY	SY	CY	SY	LF	
Munding Drive												
1+95	17+60	1565	25	795	4436	2909	1479	4436	4436	1479	4436	2909
Dearborn Avenue												
51+15	70+52	1937	25	21	5383	3584	1794	5383	5383	1794	5383	3584
TOTALS TO GENERAL SUMMARY					9818	6493	3273	9818	9818	3273	9818	6493

PAVEMENT MARKING SUBSUMMARY						
STATION	LOCATION	SIDE	642			
			LANE LINE, 4 INCH	CHANNELIZING LINE, 4 INCH	LANE ARROW	
FROM	TO		MILE	FT	EA	
1+95	17+00	MUNDING	0.29			
17+00	17+60	MUNDING		60		
17+36	17+44	MUNDING	RT			1
17+37	17+44	MUNDING	LT			1
51+15	70+37	DEARBORN		0.37		
70+37	70+52	DEARBORN			15	
69+20	69+27	DEARBORN				2
TOTALS TO GENERAL SUMMARY			0.66	75	4	

STRUCTURE SUBSUMMARY									
SHEET NO.	STATION	OFFSET (FT)	STRUCTURE NUMBER	202		605	611		
				CATCH BASIN, REMOVED	STORM SEWER, REMOVED	6" BASE PIPE UNDERDRAINS	CATCH BASIN NO. 3A	12" CONDUIT, TYPE B (706.02)	15" CONDUIT, TYPE B (706.02)
				EA	LF	FT	EA	LF	
MUNDING DRIVE									
8	4+21	25' RT	2435	1			1		
8	4+26				39			39	
8	4+31	12' LT	2434	1			1		
8	4+50				52			52	
8	4+66	27' RT	2433	1			1		
9	13+44	12' RT	2487	1			1		
9	13+44				24			24	
9	13+44	12' LT	2486	1			1		
9	16+61	12' RT	2488	1			1		
9	16+61				24			24	
9	16+61	12' LT	2489	1			1		
8 & 9	1+95 TO 17+60					2959			
DEARBORN AVENUE									
10	53+26	12' RT	416	1			1		
10	53+26				24			24	
10	53+26	12' LT	417	1			1		
10	55+00	12' RT	418	1			1		
10	55+00				24			24	
10	55+00	12' LT	419	1			1		
11	63+00	12' RT	2559	1			1		
11	63+00				24			24	
11	63+00	12' LT	2561	1			1		
11	66+00	12' RT	374	1			1		
11	66+10				33			33	
11	66+23	12' LT	373	1			1		
11	68+48	12' RT	2562	1			1		
11	68+48				24			24	
11	68+48	12' LT	2563	1			1		
11	70+36	12' RT	2445	1			1		
10 & 11	51+15 TO 70+52					3584			
TOTALS TO GENERAL SUMMARY				18	268	6543	18	196	72

01/19/23

2

DRIVEWAY SUBSUMMARY				
ADDRESS	SHEET NO.	202	452	452
		CONCRETE DRIVEWAY REMOVED	8" NON-REINFORCED CONCRETE PAVEMENT FOR DRIVEWAYS (MS), APP	6" NON-REINFORCED CONCRETE PAVEMENT FOR DRIVEWAYS (MS), APP
		SF	SF	SF
2460 Navarre Ave	9	165	165	
2460 Navarre Ave	9	222	222	
2460 Navarre Ave	9	150	150	
812 Mambriano Rd	10	32		32
1300 Dearborn Ave	10	55		55
1300 Dearborn Ave	10	55		55
1304 Dearborn Ave	10	45		45
1314 Dearborn Ave	10	45		45
1324 Dearborn Ave	10	45		45
1360 Dearborn Ave	11	38		38
TOTALS TO GENERAL SUMMARY		852	537	315

SCALE

DATE 8/12/2021

DRAWN: BEB CHECKED: RMS

SUB SUMMARIES

LUC - MUNDING DRIVE AND DEARBORN AVENUE RECONSTRUCTION

TYPICAL SECTION
MUNDING DRIVE
(STA. 1+95 TO STA. 17+60)
DEARBORN AVENUE
(STA. 51+15 TO STA. 70+52)

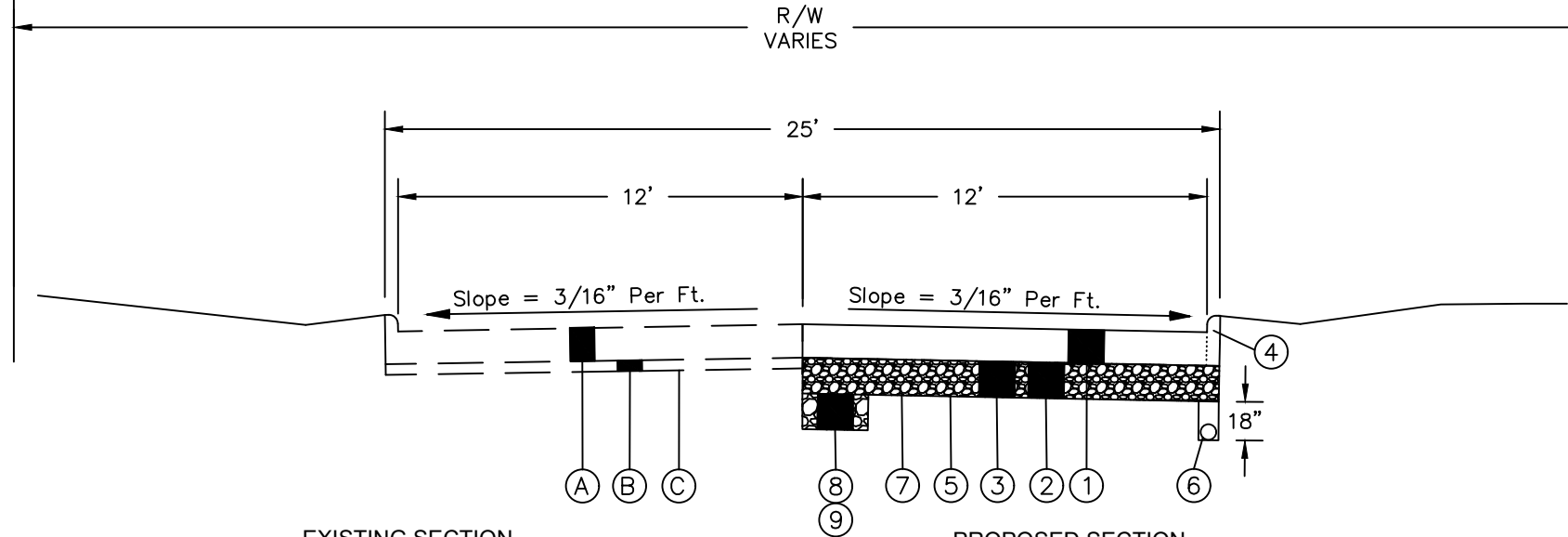

- EXISTING SECTION
- Ⓐ EXISTING 8" CONCRETE PAVEMENT
 - Ⓑ EXISTING 2"-4" CRUSHED STONE
 - Ⓒ EXISTING SUBGRADE

- PROPOSED SECTION
- ① ITEM 452 - 8" NON-REINFORCED CONCRETE PAVEMENT (MS)
 - ② ITEM 304 - 12" AGGREGATE BASE
 - ③ ITEM 203 - 12" EXCAVATION
 - ④ ITEM 609 - CURB, TYPE 2-A (MS), APP 01/19/23
 - ⑤ ITEM 204 - SUBGRADE COMPACTION
 - ⑥ ITEM 605 - 6" BASE PIPE UNDERDRAINS, APP
 - ⑦ ITEM SPEC - GEOTEXTILE FABRIC, TYPE D
 - ⑧ ITEM 203 - EXCAVATION, AS DIRECTED
 - ⑨ ITEM 204 - GRANULAR MATERIAL, TYPE C, AS DIRECTED

NOTE: COST FOR ITEM 605 BASE PIPE UNDERDRAINS, APP SHALL INCLUDE 10' TYPE F PIPE CONNECTIONS TO TIE UNDERDRAIN INTO CURB INLETS.

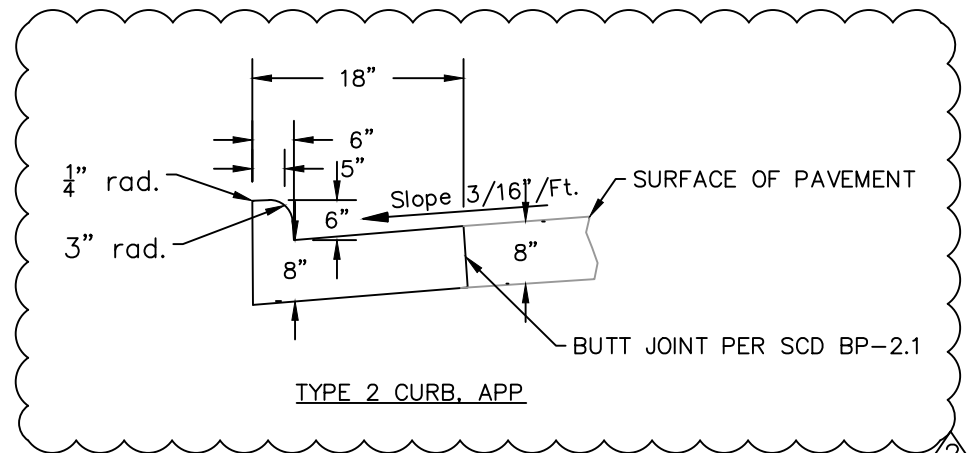

2 01/19/23

SCALE

DATE
8/12/2021

DRAWN: BEB
CHECKED: RMS

TYPICAL SECTION

LUC-MUNDING DRIVE AND DEARBORN AVENUE RECONSTRUCTION